

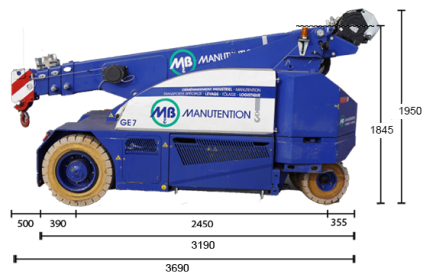

GE07 - Grue électrique 6t - JMG MC60S



Infos	Compacte - sans cabine-télécommandée-blanches
Type de JIB	Jib mécanique 4t(70kg) 3 positions 0° 22° 45° + allonge de Jib mécanique 3t(30kg)
Fourche	NON
Ballast	2 : 800 + 1160 = 1960kg
Treuil Hydraulique	Treuil 6t
Roues blanches	OUI
Radio commandé	OUI
Longueur (châssis, sans la flèche dépassante) (m)	3,19
Largeur (m)	1,38
Hauteur (m)	1,845 sans treuil / 1,95 avec treuil
Rayon de braquage (m)	2,8
Poids Grue sans jib et acc (kg)	6850
Capacité Max de levage (t)	6
Flèche Base hydraulique (m)	5,5
Petit Jib (m)	0,7
Allonge (m)	1,2 dans le petit jib
Flèche Totale Max (m)	6,7m
Hauteur sous crochet max (m)	9,5
Capacité Horizontale Portée Maxi flèche base, Crochet de base sans treuil / Geko (kg)	950
Portée : Capacité Horizontale Portée Maxi flèche base, Crochet base sans treuil / Geko (m)	5,5
Capacité Horizontale Portée Maxi flèche base grand jib(+allonge) sans treuil (kg)	700



Flèche de base avec crochet de base

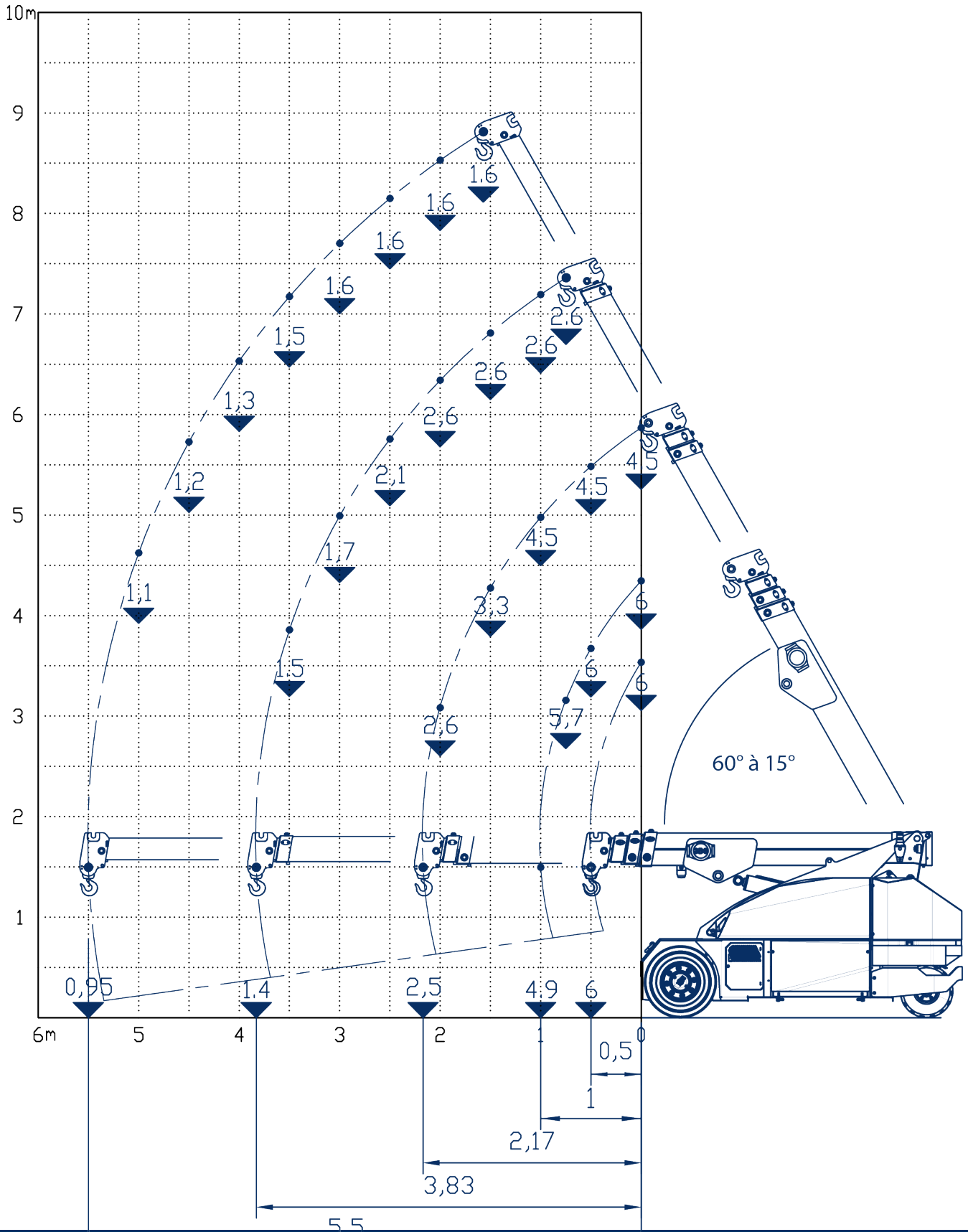

Flèche de base avec Treuil et crochet 6t

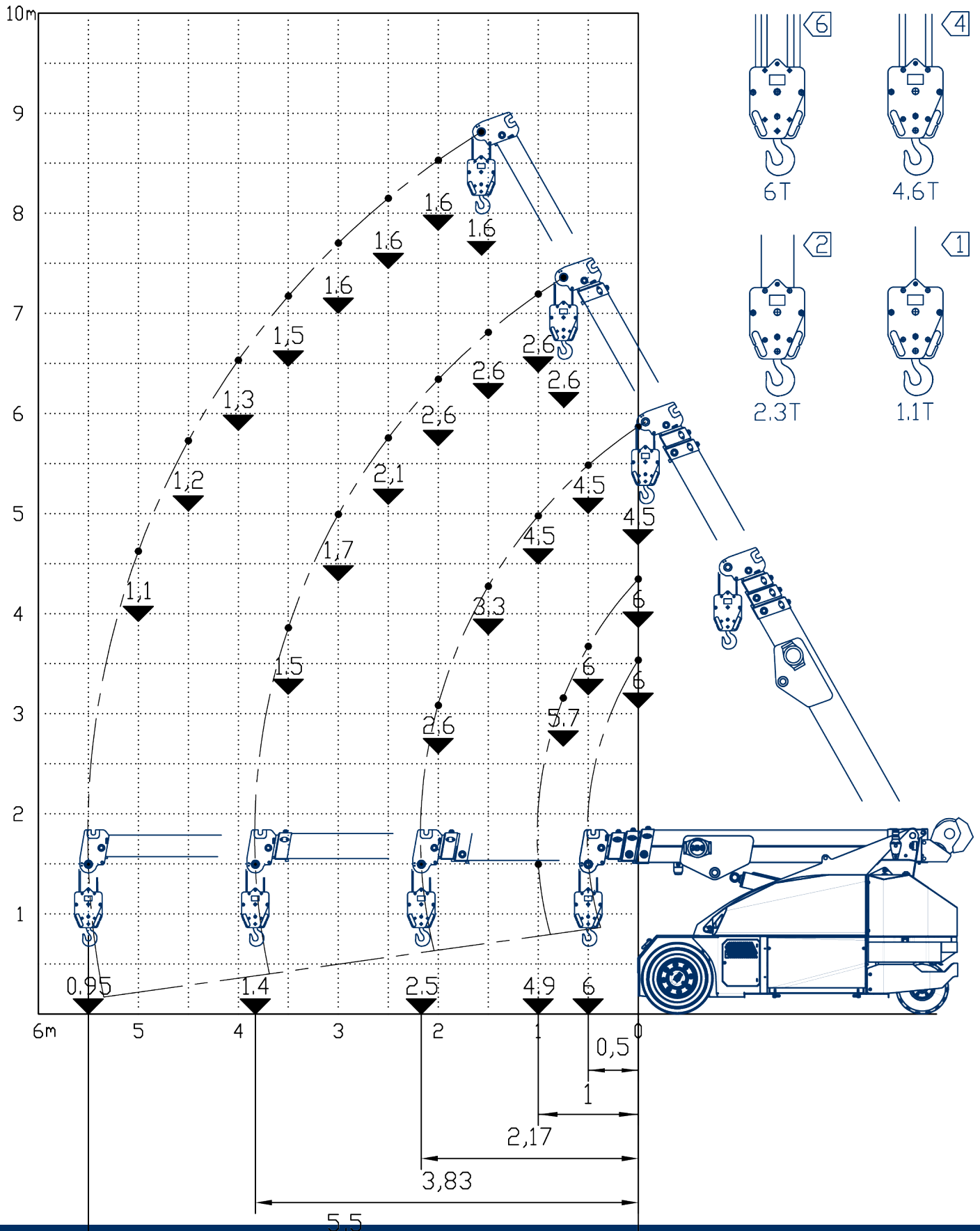

Flèche de base + Jib mécanique 4t, inclinable 3 positions 0-22-45°

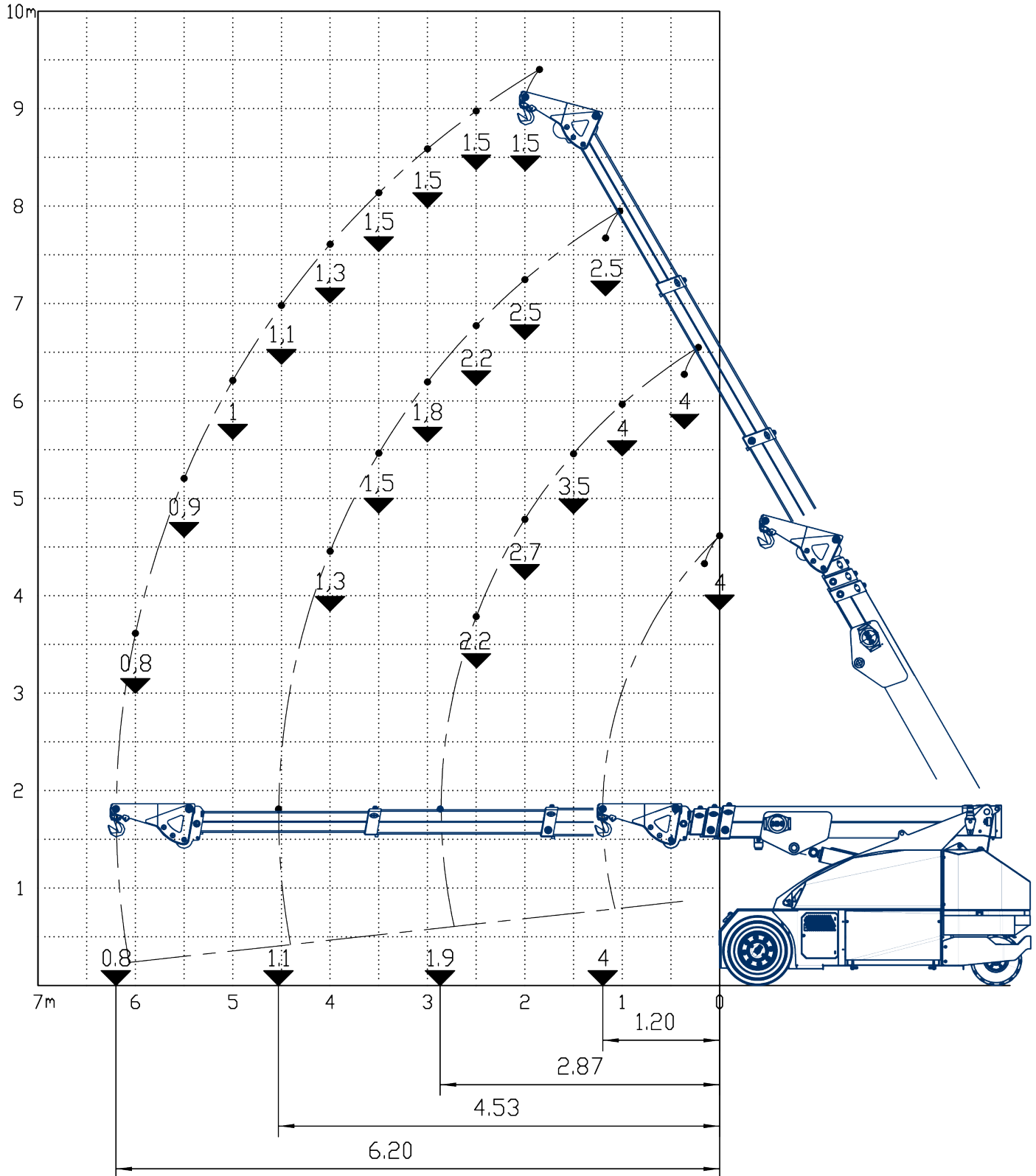

Flèche de base + Jib mécanique 4t avec Treuil, inclinable 3 positions 0-22-45°

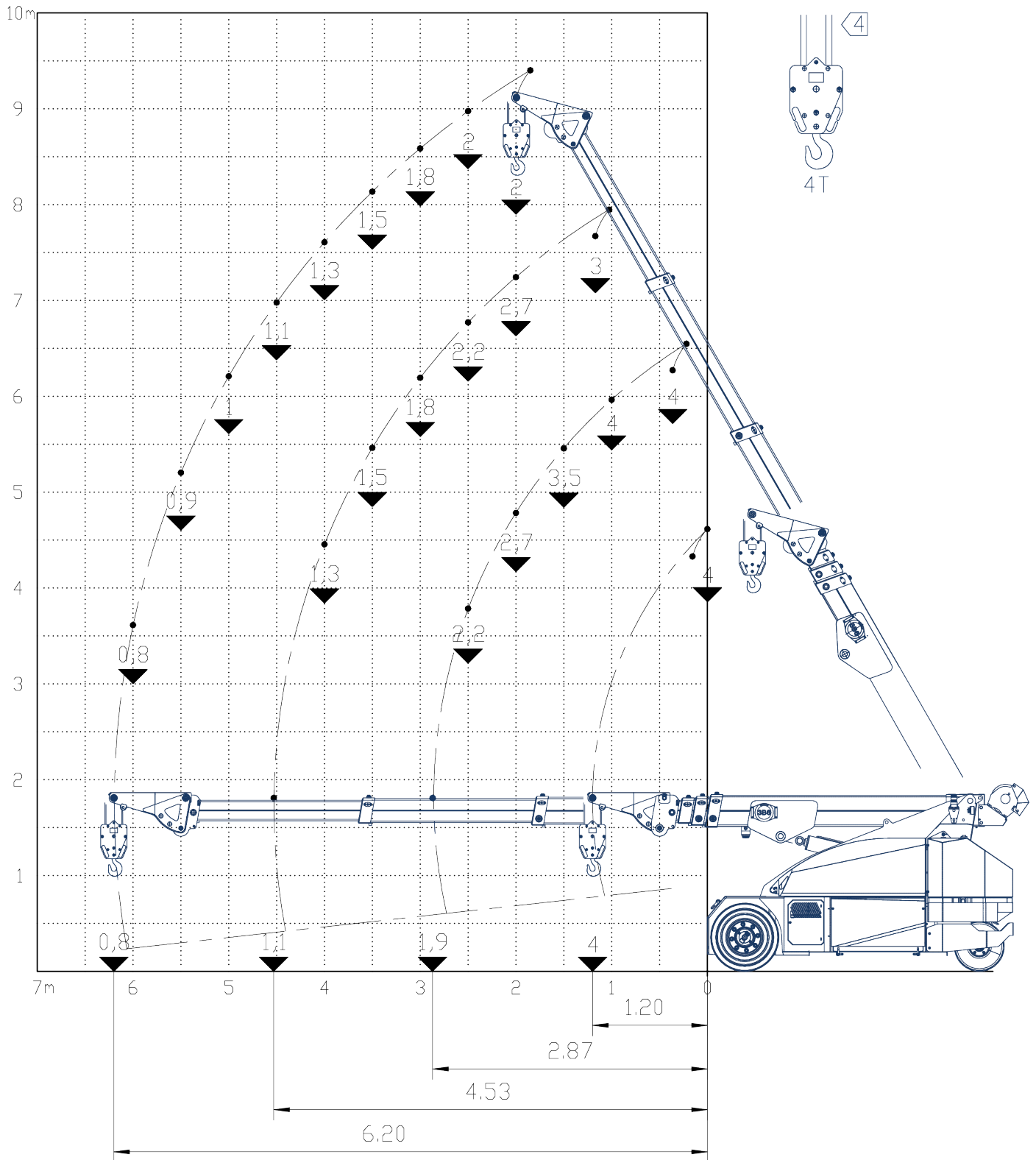

Flèche de base + Jib mécanique 4t + allonge de jib , inclinable 3 positions 0-22-45°

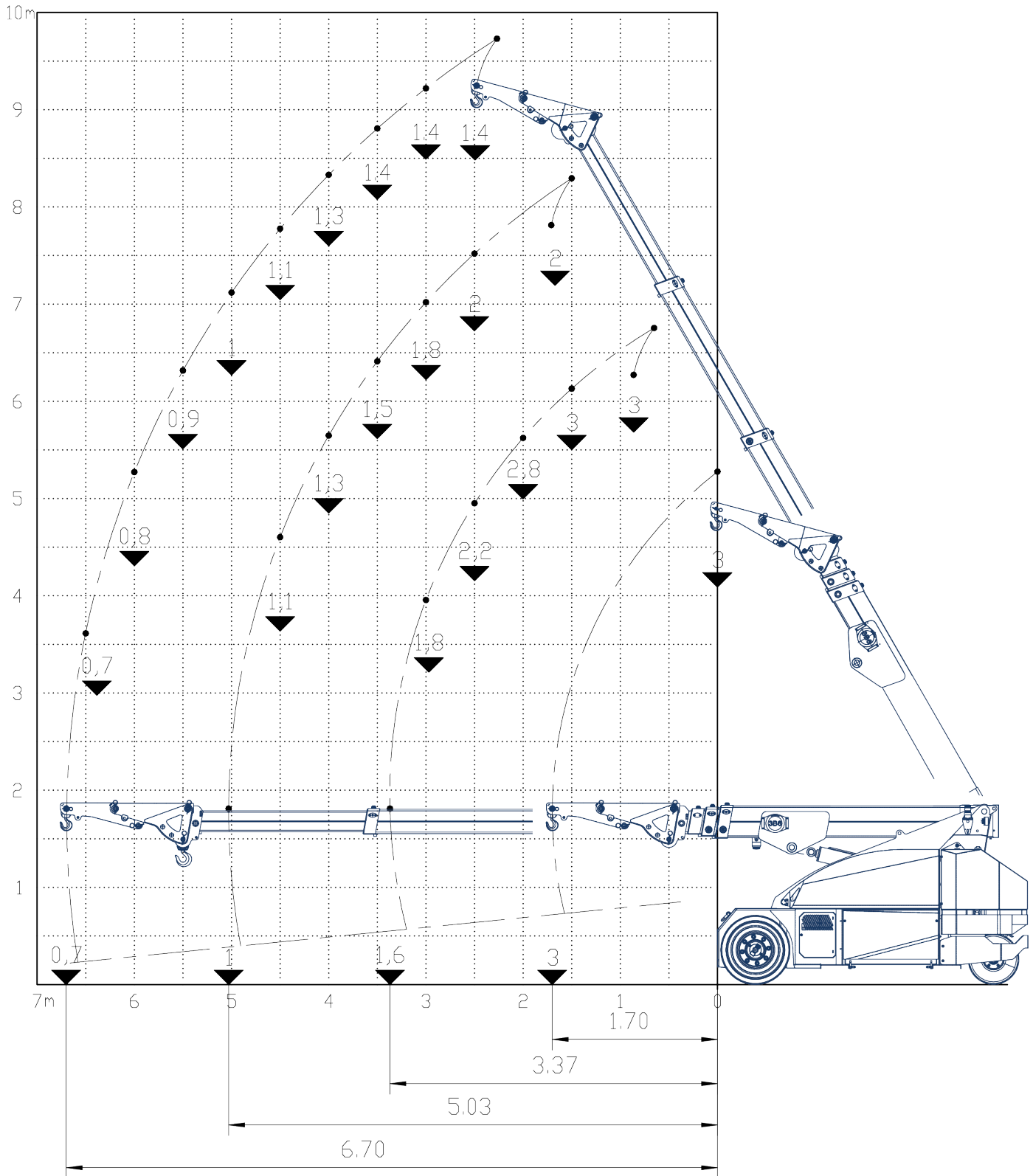

Flèche de base + Jib mécanique 4t + allonge de jib + treuil , inclinable 3 positions 0-22-45°

